

Product Details GL50



Specification

	SO	HO	SHO
Length	Any length up to 3.0m	Any length up to 3.0m	Any length up to 3.0m
Colour	3.0K/4.0K/5.0K	2.7K/3.0K/3.5K/4.0K/5.0K	2.3K/2.7K/3.0K/3.5K/4.0K/5.0K
Input Voltage	24Vdc	24Vdc	24Vdc
Power Consumption	9.6 W/m	14 W/m	18 W/m
Luminaire Efficiency	56 lm/W	78 lm/W	78 lm/W
IP Rating	IP44 or IP65	IP44 or IP65	IP44 or IP65
Type	Flush or Proud	Flush or Proud	Flush or Proud

Order code

GL50-LENGTH-OUTPUT-COLOUR-TYPE-IP-FIXING
 e.g. GL50-1.2M-SO-2.7K-FLUSH-IP44-VC

WIDTH	LENGTH	OUTPUT	COLOUR	TYPE	IP	FIXING
GL50	XXmm	SO	2.3K	Flush	IP44	S
		HO	2.7K	Proud	IP65	C
		SHO	3.0K			PLS
			3.5K			
			4.0K			
			5.0K			

Drivers

non-dimmable power supplies:
 1-10V /DALI/DMX dimmable power supplies to be ordered separately

Please call our sales team who will make sure specification suits application

Glowline by The Light Lab



Fixing Methods

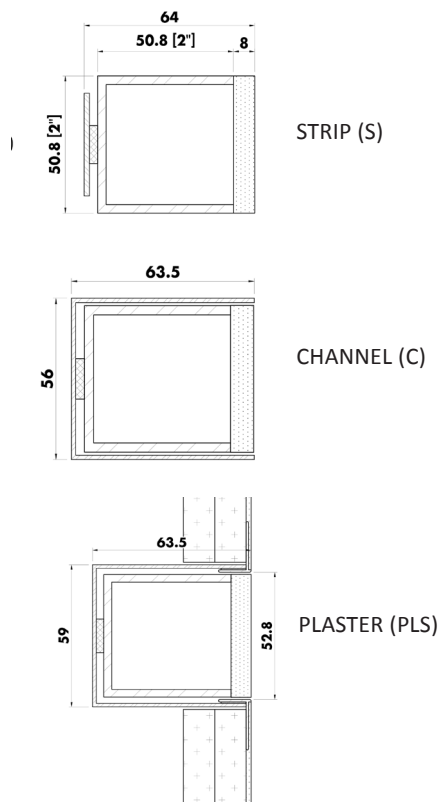

Photometric Info

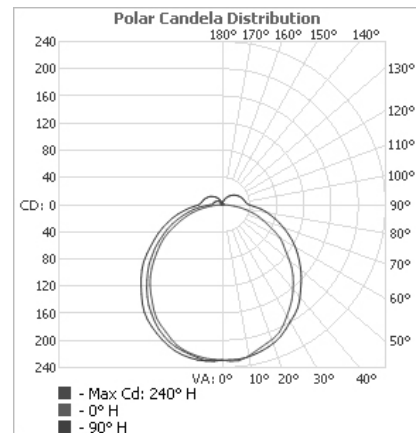

The Light Lab
 22 Holywell Row
 London EC2A 4JB
 United Kingdom
 +44 (0) 207 278 2678
 @thelightlabltd
 www.thelightlab.com